

# Cold Air Guns



**Incredible Spot Cooling for Machining Operations**  
Cold Air Guns use filtered compressed air (80-100 PSIG) and vortex tube technology to produce sub-zero air for industrial spot cooling. Cold air machining eliminates mist coolants and heat-related parts growth while improving tool life, parts tolerance and surface finish quality.

## Applications

Cold Air Guns are used in various industrial processes, fabrication, assembly and packaging as a versatile spot cooling device. Most popular applications involve cooling during the machining of metals, plastics, wood, rubber, ceramics and other materials. Cold Air Guns provide effective cooling for most dry machining operations, allowing increases in feed rates and extending tool life. With no moving parts to wear out, the internal vortex tube converts factory compressed air into a sub-zero air stream, producing temperatures down to as much as -30°F.

## Features and Benefits

- Eliminates the mess, expense and safety concerns of using mist coolants
- Avoid secondary parts cleaning after machining
- Increases dry machining speed up to 36%
- Extends tool life up to 50%
- Low pressure air output helps clear chips and dust
- Reduces grinding wheel loading caused by overheating
- Cools parts to reduce normalization time and hold tight part tolerances
- Uses only filtered compressed air - no Freon required (no CFCs/HCFCs)
- No EMI/RFI interference
- Produces cold air to 100°F below compressed air temperature
- Single turn adjustable temperature for your specific application
- Exceptionally reliable - no moving parts - quiet operation
- Magnetic base for easy installation and "machine-to-machine" portability
- Five micron filters included with Cold Air Gun Systems
- Meets OSHA noise and dead end pressure specifications

## Uses

- Widely used in milling, drilling, turning and other metalworking operations
- Machining of plastics composites, wood and other materials
- Surface grinding, drill and tool sharpening
- CNC routers, blades and band saws
- Spot cooling of parts, molds and assemblies
- Industrial sewing and textiles
- Setting hot melts and adhesives

# Cold Air Gun Spot Cooling Systems

Incredible Spot Cooling for Machining Operations.

## 610: Adjustable Cold Air Gun System

Airflow: 15 scfm (420 l/min)  
 NPT: 1/4 " (6.4 mm.)

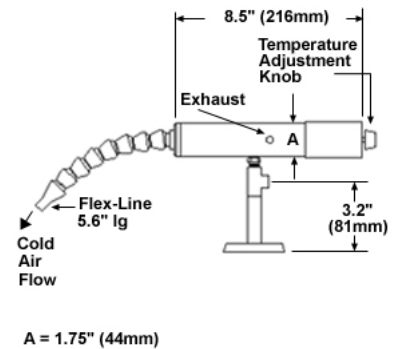

## 608: Mini Cold Air Gun System

Airflow: 8 scfm (227 l/min)  
 NPT: 1/4 " (6.4 mm.)

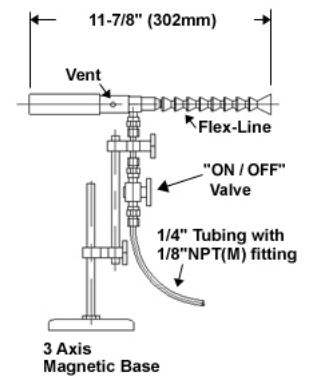

## 424: Sewing Machine Needle Cooler (59 Watts)

Power: 200 BTU/h (59 Watts, 50 kCal/h)  
 Test pressure: 100 psig (6.9 bars)  
 Airflow: 4 scfm (113 l/min)  
 NPT(F): 1/8 " (3.2 mm.)

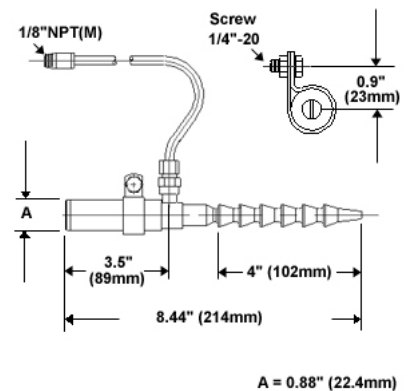
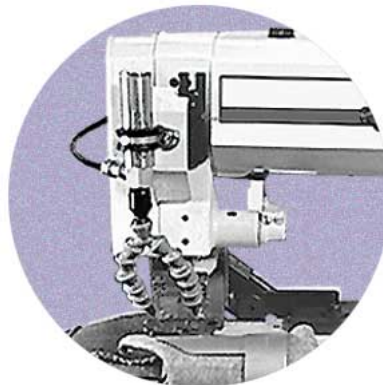

# Hot Air Gun Spot Heating Systems

Provide spot pre-heating for parts and processes.

## 609: Hot Air Gun System

NPT: 1/4 " (6.4 mm.)

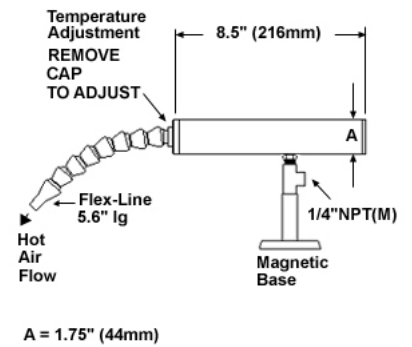
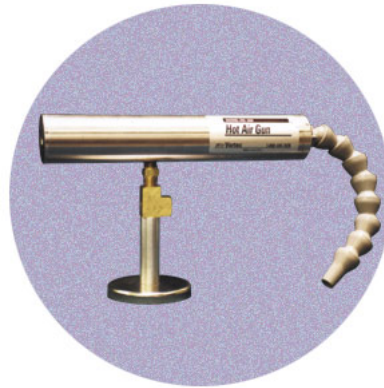

distributed by :

Newman Tools Inc.  
185 Iber Rd.  
Ottawa, Ontario, Canada K2S 1E7  
Tel 613-836-6776 Fax 613-836-9070